

REVISED 5/10/2024 BY EMMA ALMY  
 UPDATED TYPICAL SECTIONS

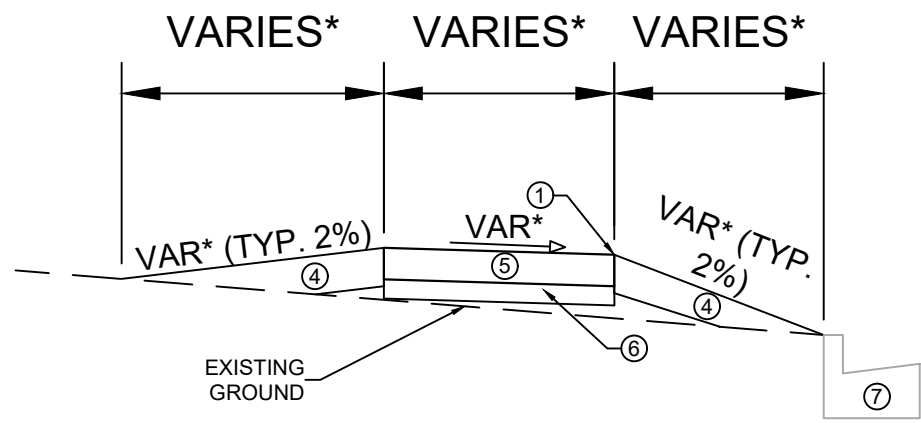

TYPICAL SECTION  
 BARTILLON PATH  
 (STA 59+25 TO STA 59+50)

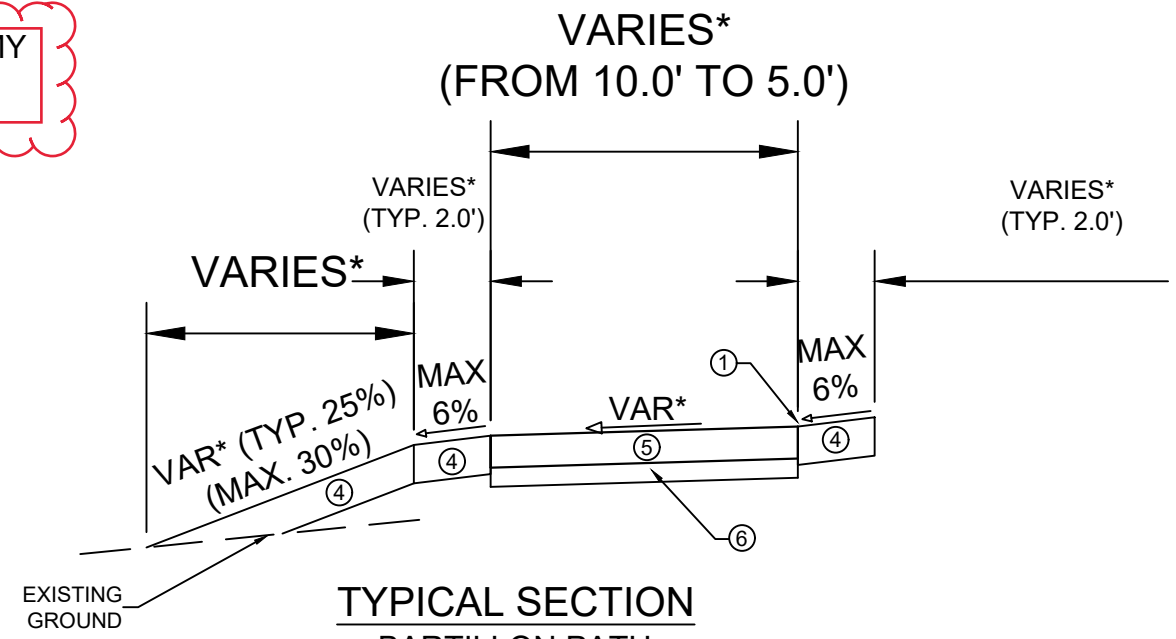

TYPICAL SECTION  
 BARTILLON PATH  
 (STA 63+91.95 TO STA 64+51.09)

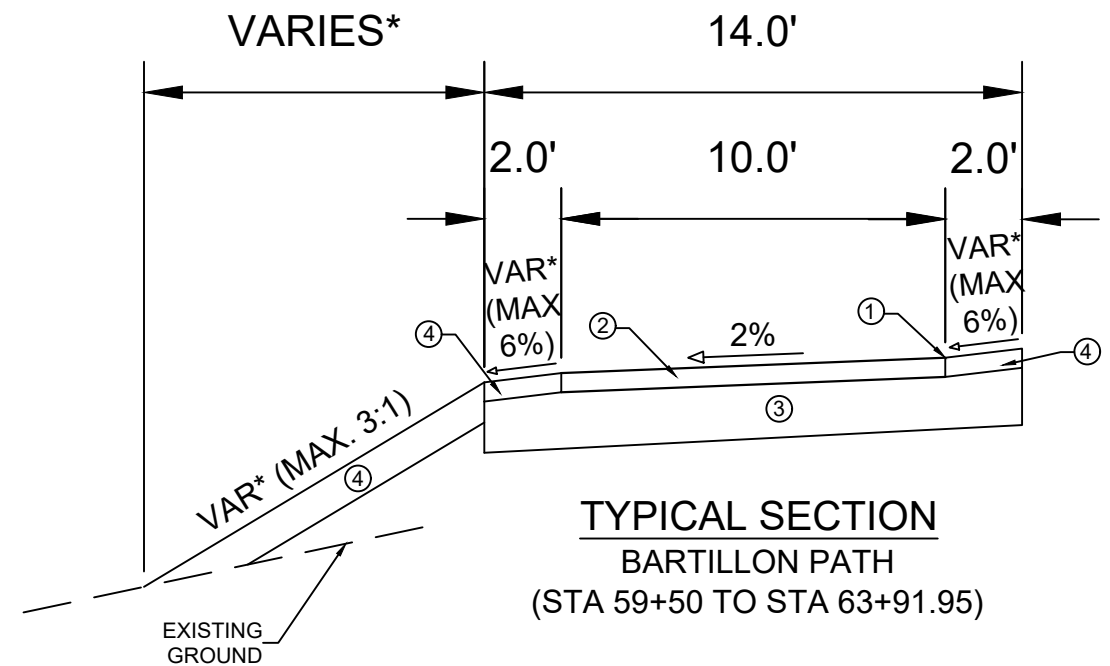

TYPICAL SECTION  
 BARTILLON PATH  
 (STA 59+50 TO STA 63+91.95)

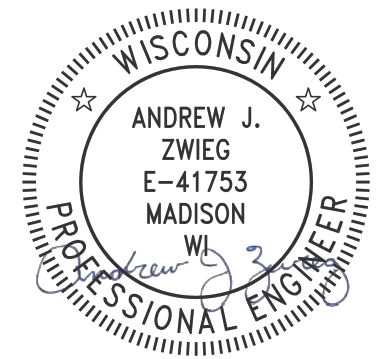

May 15, 2024

NOTES:

\* SEE PLAN AND CROSS SECTIONS FOR DETAILS AND DIMENSIONS

- ① POINT REFERRED TO ON PROFILE
- ② 3.0" H.M.A. PAVEMENT- TYPE 4 LT 58-28 S
- ③ 8" CRUSHED AGGREGATE BASE COURSE GRADATION 2
- ④ 6" TOPSOIL, SEED AND EROSION MATTING
- ⑤ 5" CONCRETE SIDEWALK
- ⑥ 3" SELECT FILL
- ⑦ EXISTING CURB

DATE	BY
04/24/2024	12:30 PM
REVISION	Scale:
MARK	14890
Designed By: EEA	

14890  
 MADISON, WI  
 8757  
 CONTRACT NO:

TYPICAL SECTIONS  
 BARTILLON PATH  
 M:\DESIGN\Projects\14890\CAD\Streets\14890EN-Details\_BidSet.dwg



14890  
 D-1

# N. STOUGHTON ROAD

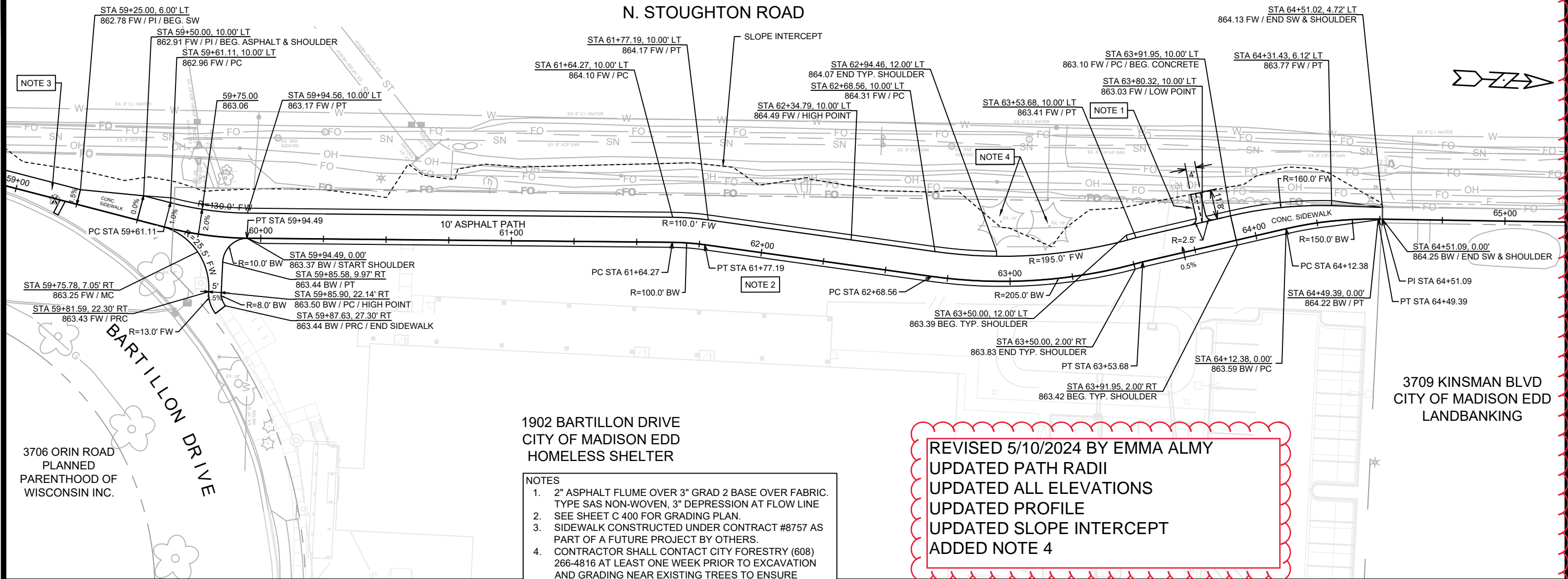

1902 BARTILLON DRIVE  
CITY OF MADISON EDD  
HOMELESS SHELTER

- NOTES**
- 2" ASPHALT FLUME OVER 3" GRAD 2 BASE OVER FABRIC. TYPE SAS NON-WOVEN, 3" DEPRESSION AT FLOW LINE
  - SEE SHEET C 400 FOR GRADING PLAN.
  - SIDEWALK CONSTRUCTED UNDER CONTRACT #8757 AS PART OF A FUTURE PROJECT BY OTHERS.
  - CONTRACTOR SHALL CONTACT CITY FORESTRY (608) 266-4816 AT LEAST ONE WEEK PRIOR TO EXCAVATION AND GRADING NEAR EXISTING TREES TO ENSURE FORESTRY STAFF IS ON-SITE.

**REVISED 5/10/2024 BY EMMA ALMY**  
**UPDATED PATH RADII**  
**UPDATED ALL ELEVATIONS**  
**UPDATED PROFILE**  
**UPDATED SLOPE INTERCEPT**  
**ADDED NOTE 4**

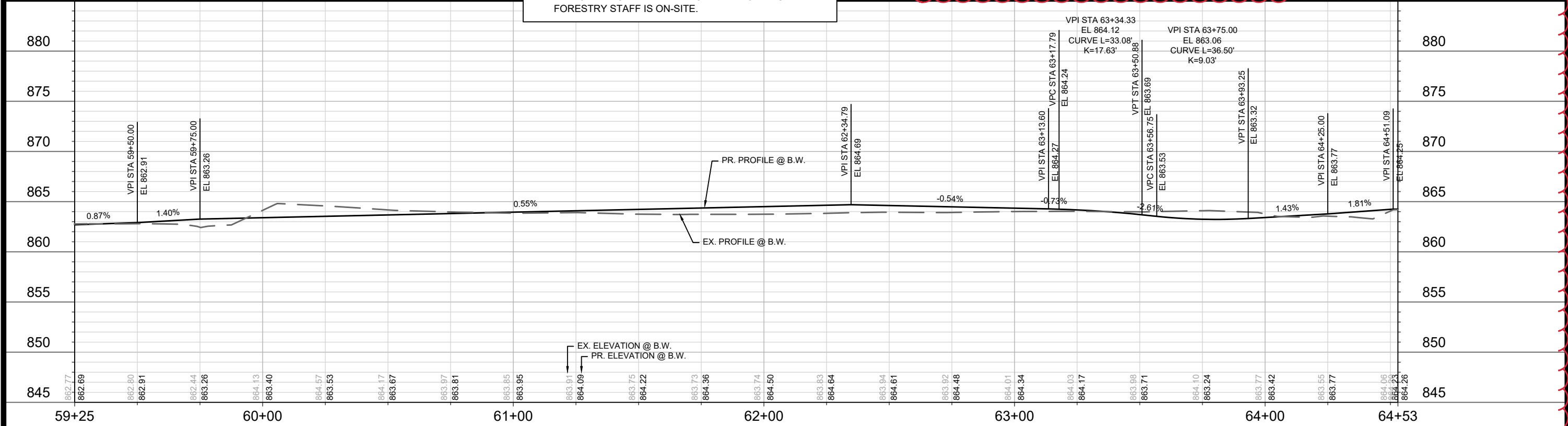

DATE	BY	P-1
REVISION	SCALE: 1" = 40'	
MARK	DESIGNED BY: EEA	DATE: 04/23/2024 11:00 AM
14890	14890	8757
CONTRACT NO:		
14890		
MADISON, WI		
PLAN & PROFILE - BARTILLON PATH		
BARTILLON PATH		
M:\DESIGN\Projects\14890\CAD\Streets\14890EN-PnP.dwg		
CITY OF MADISON WISCONSIN		
14890		
P-1		

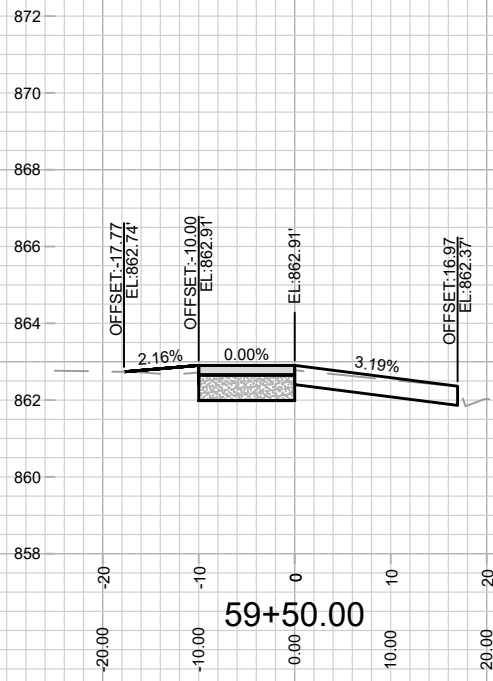

REVISED 5/10/2024 BY EMMA ALMY  
UPDATED CROSS SECTIONS

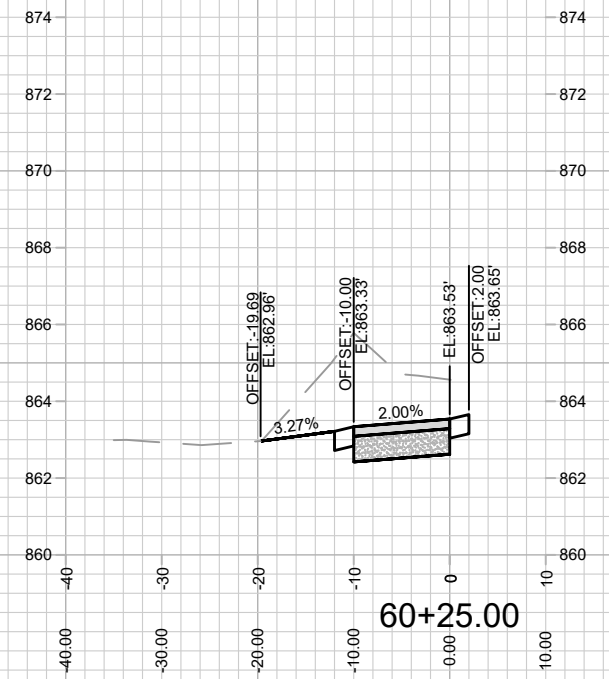
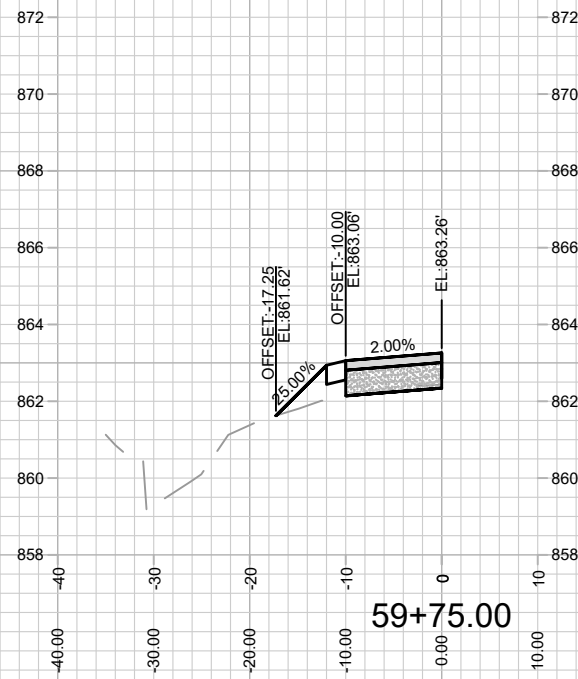
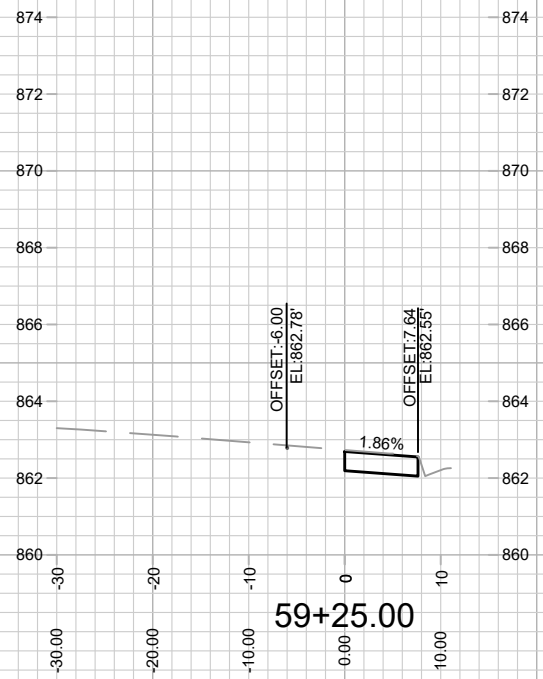
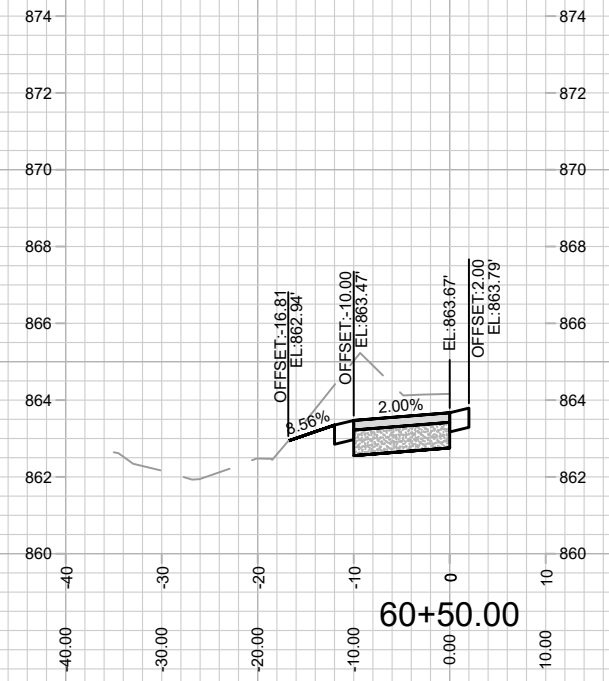
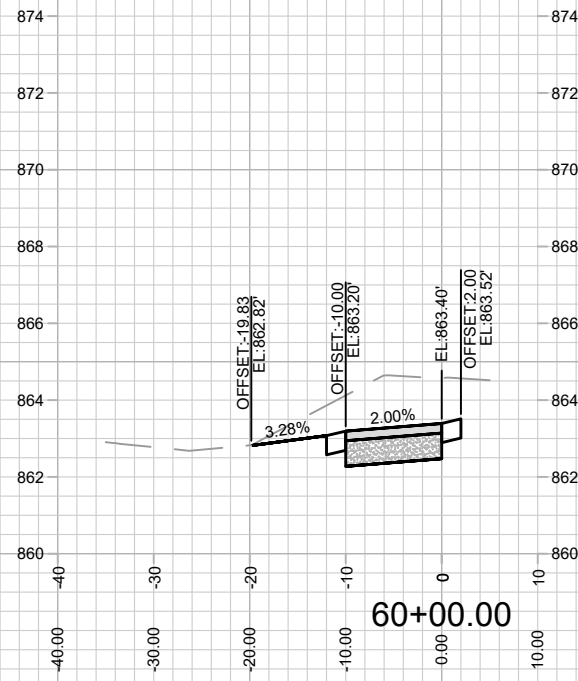

MARK	REVISION	DATE	BY

14890  
MADISON, WI  
CONTRACT NO: 8757

CROSS SECTIONS - BARTILLON PATH  
BARTILLON PATH  
M:\DESIGN\Projects\14890\CAD\Streets\14890EN-XSections.dwg



14890  
X-1

Designed By: EEA  
Date: 04/24/2024 11:00 AM  
Scale: 1" = 20'  
X-1

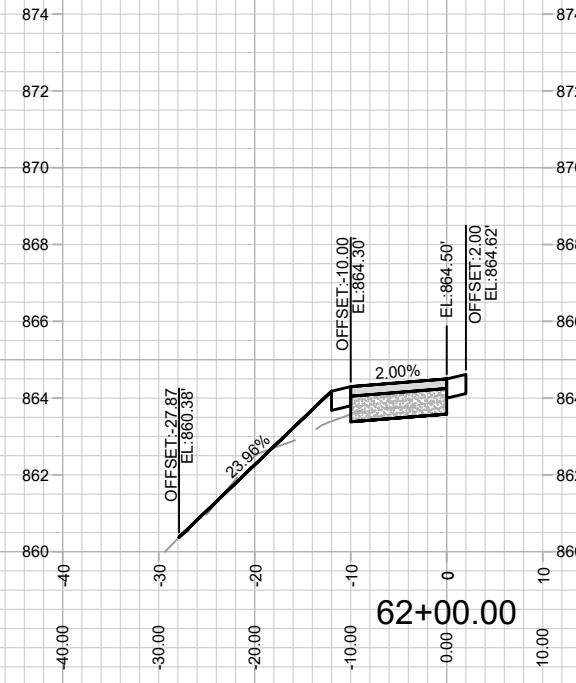
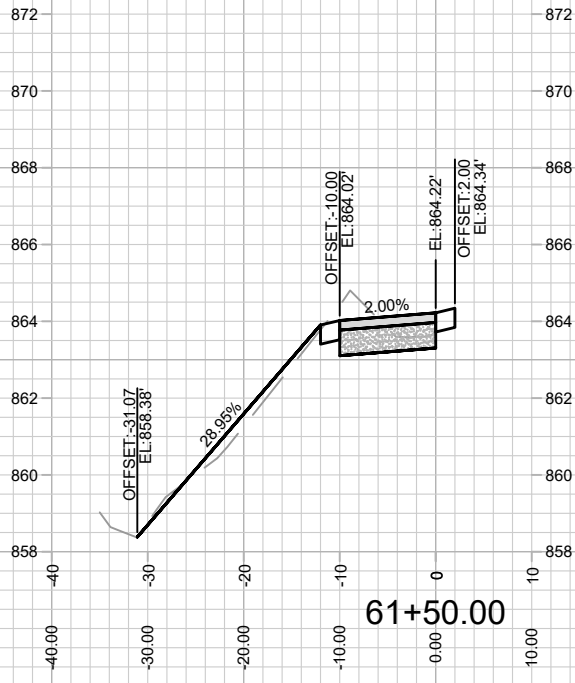
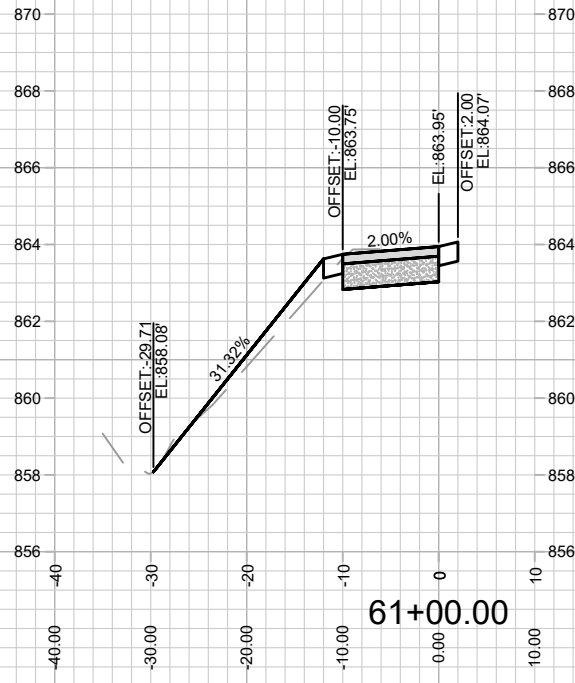

REVISED 5/10/2024 BY EMMA ALMY  
UPDATED CROSS SECTIONS

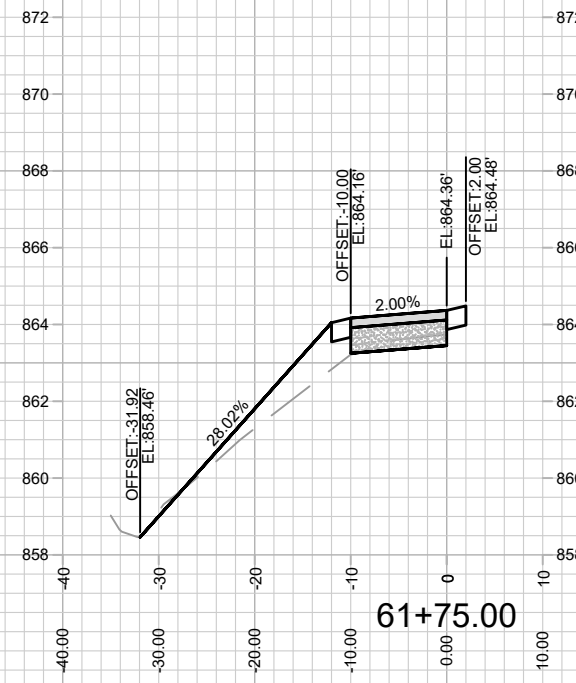
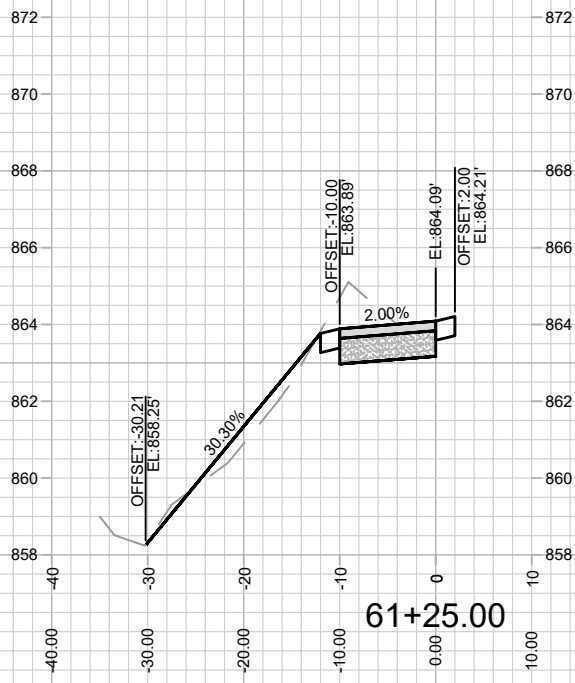
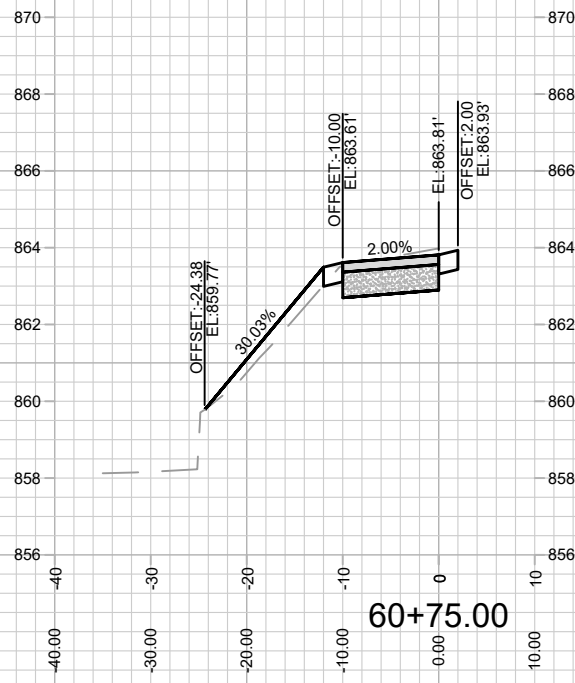

MARK	REVISION	DATE	BY
Designed By: EEA			Date: 04/24/2024 11:00 AM
14890			Scale: 1" = 20'
			X-2

14890  
MADISON, WI  
8757  
CONTRACT NO:

CROSS SECTIONS - BARTILLON PATH  
BARTILLON PATH  
M:\DESIGN\Projects\14890\CAD\Streets\14890EN-XSections.dwg

14890  
X-2

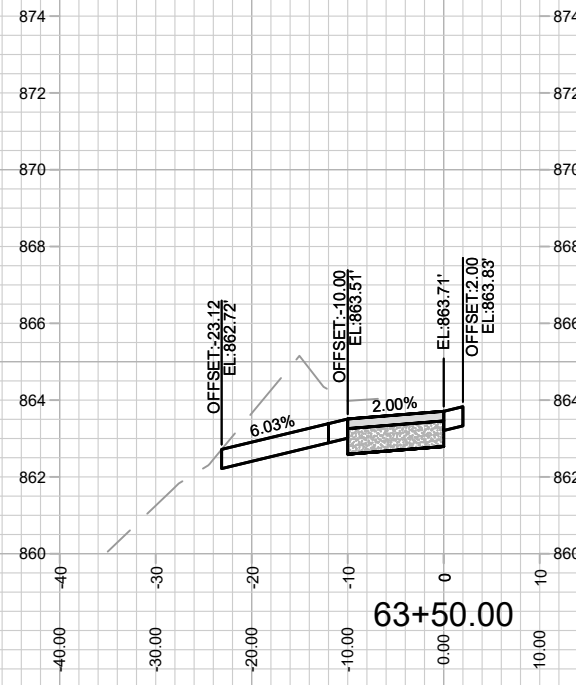
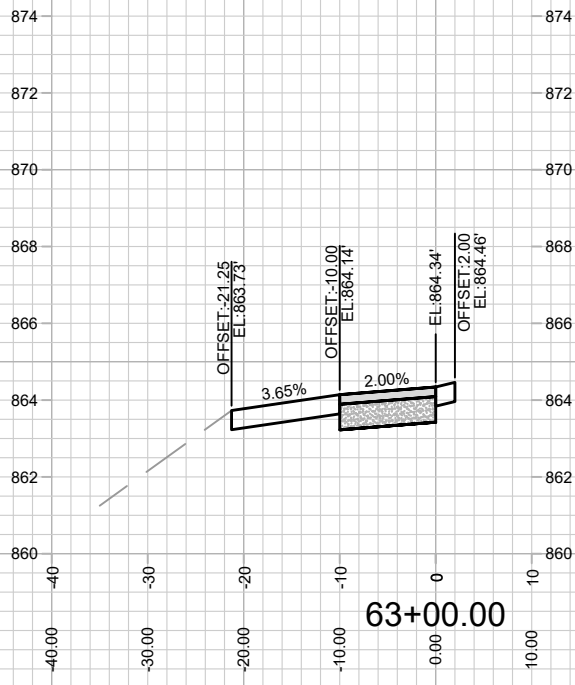
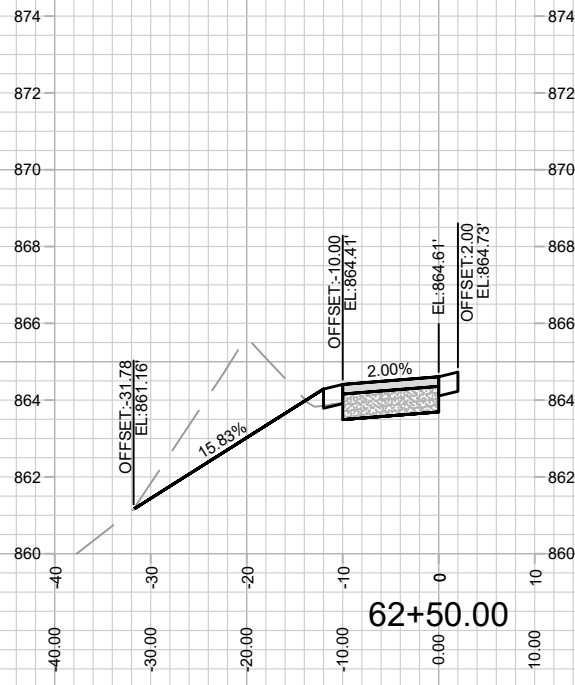

REVISED 5/10/2024 BY EMMA ALMY  
UPDATED CROSS SECTIONS

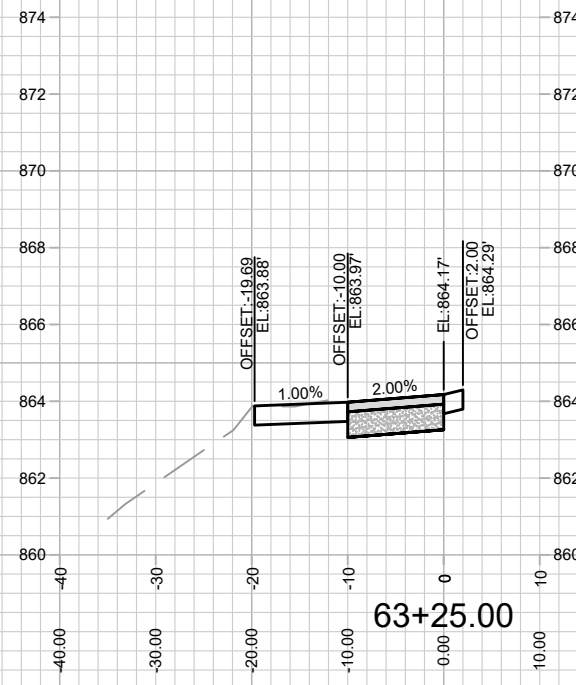
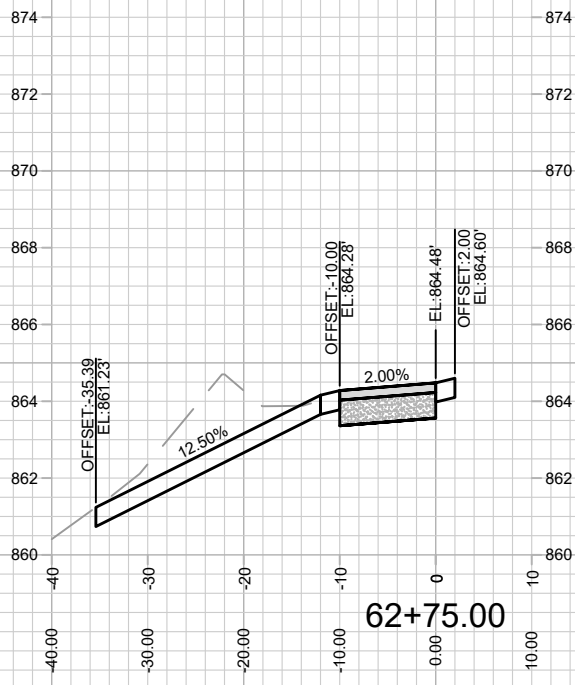
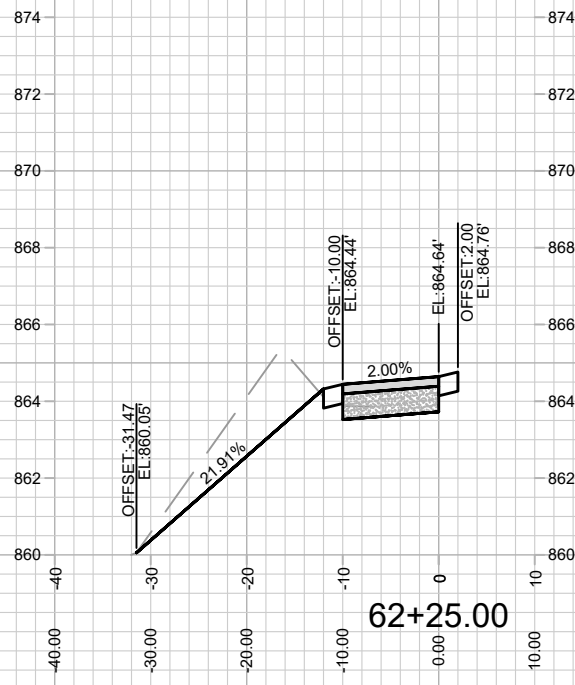

MARK	REVISION	DATE	BY
14890	Designed By: EEA	Date: 04/24/2024 11:00 AM	Scale: 1" = 20'

14890  
MADISON, WI  
CONTRACT NO: 8757

CROSS SECTIONS - BARTILLON PATH  
BARTILLON PATH  
M:\DESIGN\Projects\14890\CAD\Streets\14890\EN-XSections.dwg

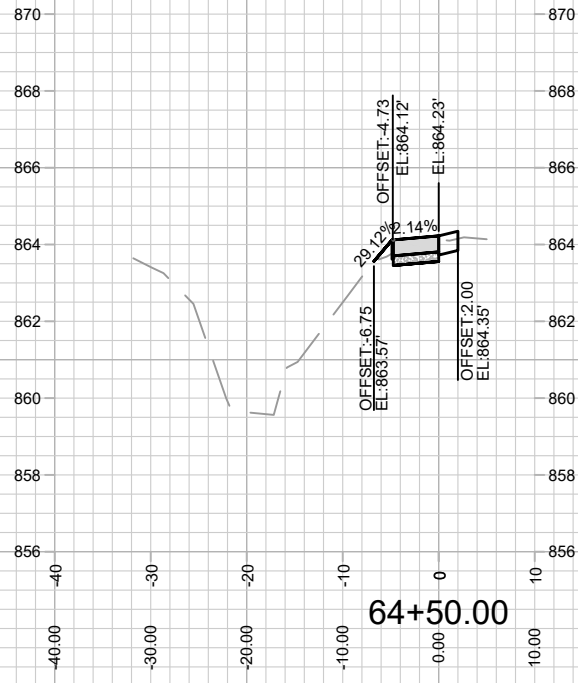
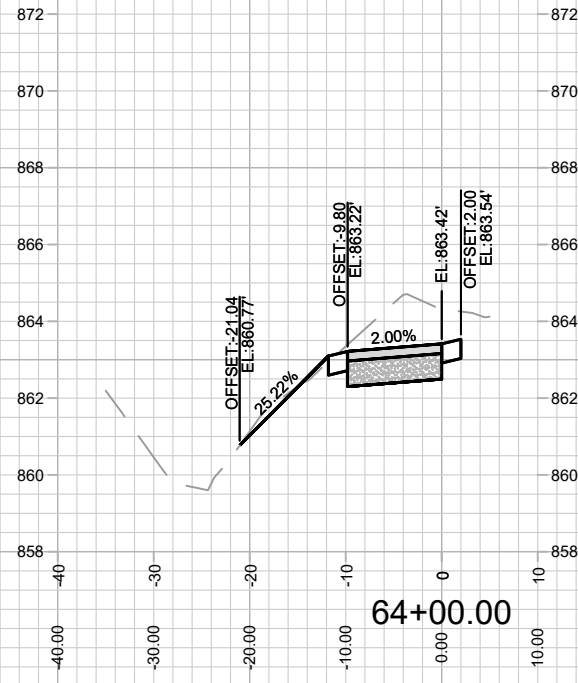

REVISED 5/10/2024 BY EMMA ALMY  
 UPDATED CROSS SECTIONS

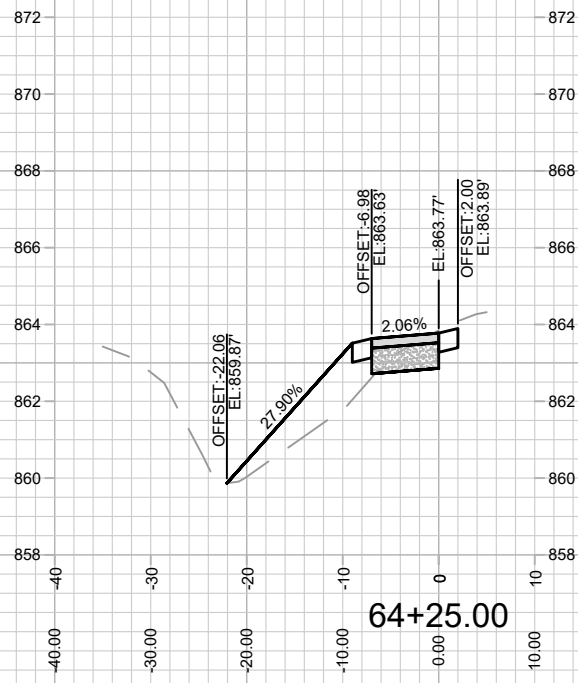
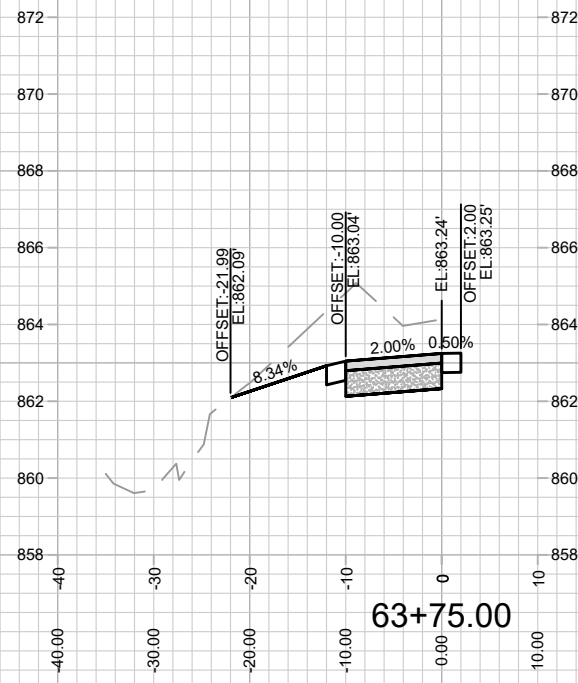

MARK	REVISION	DATE	BY
14890	14890	04/24/2024 11:00 AM	X-4

14890  
 MADISON, WI  
 CONTRACT NO: 8757

CROSS SECTIONS - BARTILLON PATH  
 BARTILLON PATH  
 M:\DESIGN\Projects\14890\CAD\Streets\14890\EN-XSections.dwg